

Series **GEFH1/C**



SET ~ 3



प्रश्न-पत्र कोड
Q.P. Code **55/C/3**

रोल नं.

Roll No.



परीक्षार्थी प्रश्न-पत्र कोड को उत्तर-पुस्तिका के मुख-पृष्ठ पर अवश्य लिखें ।

Candidates must write the Q.P. Code on the title page of the answer-book. *

भौतिक विज्ञान (सैद्धान्तिक) PHYSICS (Theory)

निर्धारित समय : 3 घण्टे

अधिकतम अंक : 70

Time allowed : 3 hours

Maximum Marks : 70

नोट / NOTE :

- (i) कृपया जाँच कर लें कि इस प्रश्न-पत्र में मुद्रित पृष्ठ 27 हैं ।
Please check that this question paper contains 27 printed pages.
- (ii) प्रश्न-पत्र में दाहिने हाथ की ओर दिए गए प्रश्न-पत्र कोड को परीक्षार्थी उत्तर-पुस्तिका के मुख-पृष्ठ पर लिखें ।
Q.P. Code given on the right hand side of the question paper should be written on the title page of the answer-book by the candidate.
- (iii) कृपया जाँच कर लें कि इस प्रश्न-पत्र में 35 प्रश्न हैं ।
Please check that this question paper contains 35 questions.
- (iv) कृपया प्रश्न का उत्तर लिखना शुरू करने से पहले, उत्तर-पुस्तिका में प्रश्न का क्रमांक अवश्य लिखें ।
Please write down the serial number of the question in the answer-book before attempting it.
- (v) इस प्रश्न-पत्र को पढ़ने के लिए 15 मिनट का समय दिया गया है । प्रश्न-पत्र का वितरण पूर्वाह्न में 10.15 बजे किया जाएगा । 10.15 बजे से 10.30 बजे तक छात्र केवल प्रश्न-पत्र को पढ़ेंगे और इस अवधि के दौरान वे उत्तर-पुस्तिका पर कोई उत्तर नहीं लिखेंगे ।
15 minute time has been allotted to read this question paper. The question paper will be distributed at 10.15 a.m. From 10.15 a.m. to 10.30 a.m., the students will read the question paper only and will not write any answer on the answer-book during this period.





सामान्य निर्देश :

निम्नलिखित निर्देशों को बहुत सावधानी से पढ़िए और उनका सख्ती से पालन कीजिए :

- (i) इस प्रश्न-पत्र में 35 प्रश्न हैं। सभी प्रश्न अनिवार्य हैं।
- (ii) यह प्रश्न-पत्र पाँच खण्डों में विभाजित है – क, ख, ग, घ एवं ङ।
- (iii) खण्ड क में प्रश्न संख्या 1 से 18 तक बहुविकल्पीय (MCQ) प्रकार के एक-एक अंक के प्रश्न हैं।
- (iv) खण्ड ख में प्रश्न संख्या 19 से 25 तक अति लघु-उत्तरीय (VSA) प्रकार के दो-दो अंकों के प्रश्न हैं।
- (v) खण्ड ग में प्रश्न संख्या 26 से 30 तक लघु-उत्तरीय (SA) प्रकार के तीन-तीन अंकों के प्रश्न हैं।
- (vi) खण्ड घ में प्रश्न संख्या 31 से 33 तक दीर्घ-उत्तरीय (LA) प्रकार के पाँच-पाँच अंकों के प्रश्न हैं।
- (vii) खण्ड ङ में प्रश्न संख्या 34 तथा 35 केस-आधारित चार-चार अंकों के प्रश्न हैं।
- (viii) प्रश्न-पत्र में समग्र विकल्प नहीं दिया गया है। यद्यपि, खण्ड ख के 2 प्रश्नों में, खण्ड ग के 2 प्रश्नों में, खण्ड घ के 3 प्रश्नों में तथा खण्ड ङ के 2 प्रश्नों में आंतरिक विकल्प का प्रावधान दिया गया है।
- (ix) कैल्कुलेटर का उपयोग वर्जित है।

भौतिक नियतांकों के निम्नलिखित मान, आवश्यकता अनुसार उपयोग करें :

$$c = 3 \times 10^8 \text{ m/s}$$

$$h = 6.63 \times 10^{-34} \text{ Js}$$

$$e = 1.6 \times 10^{-19} \text{ C}$$

$$\mu_0 = 4\pi \times 10^{-7} \text{ T m A}^{-1}$$

$$\epsilon_0 = 8.854 \times 10^{-12} \text{ C}^2 \text{ N}^{-1} \text{ m}^{-2}$$

$$\frac{1}{4\pi\epsilon_0} = 9 \times 10^9 \text{ N m}^2 \text{ C}^{-2}$$

$$\text{इलेक्ट्रॉन का द्रव्यमान (} m_e \text{)} = 9.1 \times 10^{-31} \text{ kg}$$

$$\text{न्यूट्रॉन का द्रव्यमान} = 1.675 \times 10^{-27} \text{ kg}$$

$$\text{प्रोटॉन का द्रव्यमान} = 1.673 \times 10^{-27} \text{ kg}$$

$$\text{आवोगाद्रो संख्या} = 6.023 \times 10^{23} \text{ प्रति ग्राम मोल (per gram mole)}$$

$$\text{बोल्ट्ज़मान नियतांक} = 1.38 \times 10^{-23} \text{ JK}^{-1}$$





General Instructions :

Read the following instructions very carefully and strictly follow them :

- (i) This question paper contains **35** questions. **All** questions are **compulsory**.
- (ii) This question paper is divided into **five** Sections – **A, B, C, D** and **E**.
- (iii) In **Section A** – Questions no. **1** to **18** are Multiple Choice (MCQ) type questions, carrying **1** mark each.
- (iv) In **Section B** – Questions no. **19** to **25** are Very Short Answer (VSA) type questions, carrying **2** marks each.
- (v) In **Section C** – Questions no. **26** to **30** are Short Answer (SA) type questions, carrying **3** marks each.
- (vi) In **Section D** – Questions no. **31** to **33** are Long Answer (LA) type questions carrying **5** marks each.
- (vii) In **Section E** – Questions no. **34** and **35** are case-based questions carrying **4** marks each.
- (viii) There is no overall choice. However, an internal choice has been provided in 2 questions in Section B, 2 questions in Section C, 3 questions in Section D and 2 questions in Section E.
- (ix) Use of calculators is **not** allowed.

Use the following values of physical constants, if required :

$$c = 3 \times 10^8 \text{ m/s}$$

$$h = 6.63 \times 10^{-34} \text{ Js}$$

$$e = 1.6 \times 10^{-19} \text{ C}$$

$$\mu_0 = 4\pi \times 10^{-7} \text{ T m A}^{-1}$$

$$\epsilon_0 = 8.854 \times 10^{-12} \text{ C}^2 \text{ N}^{-1} \text{ m}^{-2}$$

$$\frac{1}{4\pi\epsilon_0} = 9 \times 10^9 \text{ N m}^2 \text{ C}^{-2}$$

$$\text{Mass of electron (} m_e \text{)} = 9.1 \times 10^{-31} \text{ kg}$$

$$\text{Mass of neutron} = 1.675 \times 10^{-27} \text{ kg}$$

$$\text{Mass of proton} = 1.673 \times 10^{-27} \text{ kg}$$

$$\text{Avogadro's number} = 6.023 \times 10^{23} \text{ per gram mole}$$

$$\text{Boltzmann constant} = 1.38 \times 10^{-23} \text{ JK}^{-1}$$



खण्ड क

1. कोई विद्युत द्विध्रुव जिसका द्विध्रुव आघूर्ण $\vec{P} = P_0 \hat{i} - P_0 \hat{j}$ है, किसी विद्युत क्षेत्र $\vec{E} = E_1 \hat{i} + E_2 \hat{j}$ में स्थित है, जहाँ P_0 , E_1 और E_2 स्थिरांक हैं। इस द्विध्रुव पर कार्यरत बल आघूर्ण $\vec{\tau}$ है :

- (a) $P_0(E_2 - E_1) \hat{k}$ (b) $P_0(E_2 + E_1) \hat{k}$
(c) $-P_0(E_2 + E_1) \hat{k}$ (d) $P_0(E_1 - E_2) \hat{k}$

2. त्रिज्या r के किसी चालक से प्रवाहित धारा I उसके अनुप्रस्थ-काट पर एकसमान वितरित है। इस चालक के अक्ष से दूरी x के साथ चुम्बकीय क्षेत्र \vec{B} के परिमाण के विचरण को निम्नलिखित में से कौन-सा ग्राफ निरूपित करता है ?

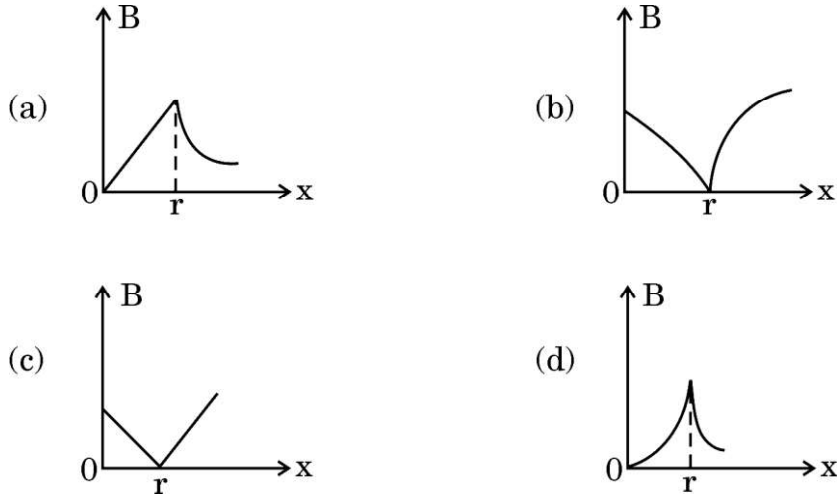

3. ध्रुव प्राबल्य (m) और चुम्बकीय आघूर्ण (M) के किसी छड़ चुम्बक को उसके अक्ष के लम्बवत दो समान भागों में काटा गया है। प्रत्येक भाग का नया ध्रुव प्राबल्य (m') और चुम्बकीय आघूर्ण (M') क्रमशः होंगे :

- (a) m और M (b) m और $\frac{M}{2}$
(c) $\frac{m}{2}$ और $2M$ (d) $2m$ और $\frac{M}{2}$





SECTION A

1. An electric dipole with dipole moment $\vec{P} = P_0 \hat{i} - P_0 \hat{j}$ is placed in an electric field $\vec{E} = E_1 \hat{i} + E_2 \hat{j}$, where P_0 , E_1 and E_2 are constants. The torque $\vec{\tau}$ acting on the dipole is :

- (a) $P_0 (E_2 - E_1) \hat{k}$ (b) $P_0 (E_2 + E_1) \hat{k}$
(c) $-P_0 (E_2 + E_1) \hat{k}$ (d) $P_0 (E_1 - E_2) \hat{k}$

2. The current I flowing through a conductor of radius r is uniformly distributed across its cross-section. Which of the following graphs represents the variation of magnitude of magnetic field \vec{B} with distance x from the axis of the conductor ?

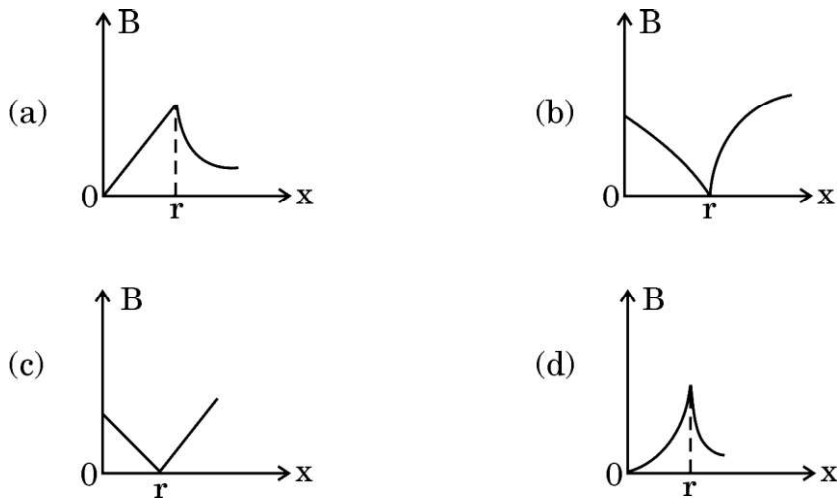

3. A bar magnet of pole strength (m) and magnetic moment (M) is cut perpendicular to its axis in two equal halves. The new pole strength (m') and magnetic moment (M') of each part are respectively :

- (a) m and M (b) m and $\frac{M}{2}$
(c) $\frac{m}{2}$ and $2M$ (d) $2m$ and $\frac{M}{2}$

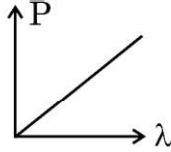
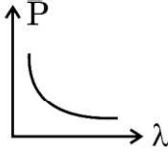
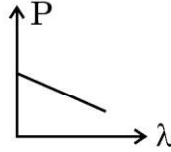
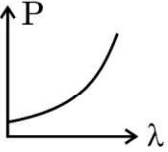

4. किसी श्रेणी LC परिपथ में, जो किसी ac स्रोत से संयोजित है, स्रोत की आवृत्ति में वृद्धि होने पर नेट प्रतिघात :
- (a) रैखिकत: बढ़ती है
(b) रैखिकत: घटती है
(c) पहले बढ़कर अधिकतम हो जाती है और फिर घटकर शून्य हो जाती है
(d) पहले घटकर शून्य हो जाती है और फिर बढ़ती है
5. निम्नलिखित में से किस विकिरण की आवृत्ति सबसे अधिक है ?
- (a) दृश्य प्रकाश
(b) अवरक्त किरणें
(c) सूक्ष्म तरंगें
(d) X-किरणें
6. यंग के द्विझिरी प्रयोग में पर्दे के किसी बिन्दु जहाँ पथान्तर λ है, वहाँ तीव्रता I_0 है । जिस बिन्दु पर पथान्तर $\frac{\lambda}{4}$ है, वहाँ तीव्रता होगी :
- (a) $\frac{I_0}{4}$ (b) $\frac{I_0}{2}$
(c) I_0 (d) शून्य
7. निम्नलिखित में से कौन-सी आकृति किसी कण के संवेग के साथ उससे संबद्ध दे ब्रॉग्ली तरंगदैर्घ्य के विचरण का निरूपण करती है ?
- (a)  (b) 
- (c)  (d) 
8. बंधन ऊर्जा प्रति न्यूक्लियॉन किसके लिए निम्नतर होता है ?
- (a) केवल हल्के नाभिकों के लिए
(b) केवल भारी नाभिकों के लिए
(c) केवल मध्य द्रव्यमान संख्याओं के नाभिकों के लिए
(d) हल्के नाभिकों और भारी नाभिकों दोनों के लिए





4. In a series LC circuit connected to an ac source, with the increase in the frequency of the source, the net reactance :
- (a) increases linearly
 - (b) decreases linearly
 - (c) first increases to become maximum and then decreases to zero
 - (d) first decreases to become zero and then increases

5. Which of the following radiations has the highest frequency ?
- (a) Visible light
 - (b) Infrared rays
 - (c) Microwaves
 - (d) X-rays

6. In Young's double-slit experiment, the intensity on the screen is I_0 at a point where path difference is λ . The intensity at the point where path difference is $\frac{\lambda}{4}$ is :

- (a) $\frac{I_0}{4}$
- (b) $\frac{I_0}{2}$
- (c) I_0
- (d) zero

7. Which of the following figures represents the variation of a particle's momentum with the de Broglie wavelength associated with it ?

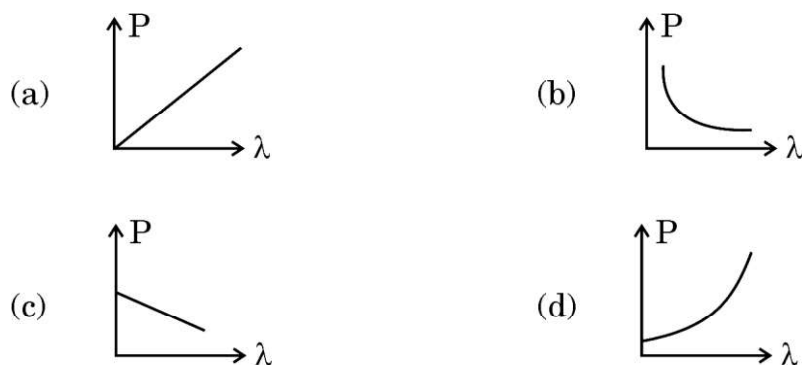

8. The binding energy per nucleon is lower :
- (a) for light nuclei only
 - (b) for heavy nuclei only
 - (c) for nuclei of middle mass numbers only
 - (d) both for the light nuclei and the heavy nuclei



9. आवृत्ति $1.5 \nu_0$ का कोई प्रकाश देहली आवृत्ति ν_0 के किसी प्रकाश-सुग्राही पदार्थ पर आपतन कर रहा है। यदि आपतित विकिरणों की आवृत्ति नियत रखते हुए उसकी तीव्रता में वृद्धि की जाए, तो प्रकाश विद्युत धारा में :
- (a) वृद्धि होगी
(b) कमी होगी
(c) कोई परिवर्तन नहीं होगा
(d) पहले कमी होगी और फिर शून्य हो जाएगी
10. दिए गए आरेख में संधारित्र C और प्रतिरोधक R को श्रेणी में किसी ac स्रोत से संयोजित दर्शाया गया है। V_1 और V_2 वोल्टमीटर और A ऐमीटर है।

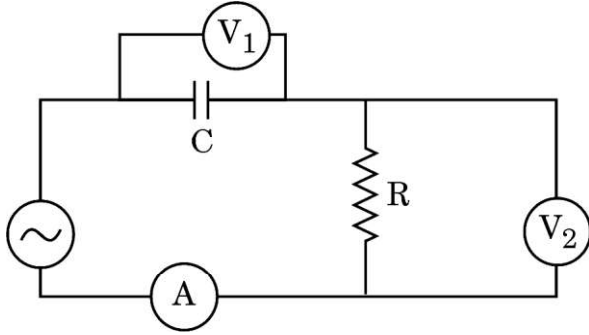

निम्नलिखित में से कौन-सा कथन सही है ?

- (a) परिपथ में धारा V_2 में दर्शायी वोल्टता के साथ कला में पश्च है।
(b) V_1 में दर्शायी वोल्टता V_2 में दर्शायी वोल्टता के साथ कला में अग्र है।
(c) परिपथ में धारा और V_1 में दर्शायी वोल्टता सदैव ही समान कला में हैं।
(d) V_1 में दर्शायी वोल्टता V_2 में दर्शायी वोल्टता के साथ कला में पश्च है।
11. दो नाभिकों की द्रव्यमान संख्या का अनुपात $1 : 27$ है। इनके नाभिकीय घनत्वों का अनुपात क्या है ?
- (a) $1 : 27$ (b) $1 : 1$
(c) $1 : 9$ (d) $1 : 3$
12. किसी लक्ष्य नाभिक का उपगमन करते समय किसी ऐल्फा कण के लिए संघट्ट प्राचल तब अधिकतम होता है जब प्रकीर्णन कोण (θ) होता है :
- (a) 0° (b) 90°
(c) 180° (d) 45°



13. किसी समतलीय पाश को उसके अक्ष के परितः किसी चुम्बकीय क्षेत्र में क्षेत्र के लम्बवत घूर्णित कराया गया है। प्रेरित वि.वा. बल (emf) की ध्रुवता एक बार परिवर्तित होती है प्रत्येक :

- (a) 1 परिक्रमण में (b) $\left(\frac{1}{2}\right)$ परिक्रमण में
(c) $\left(\frac{1}{4}\right)$ परिक्रमण में (d) $\left(\frac{3}{4}\right)$ परिक्रमण में

14. निम्नलिखित में से किस आरेख में किसी अर्धतरंग दिष्टकारी द्वारा मसृण (चिकने) निर्गत प्रदान करने के लिए संधारित्र 'C' को सही ढंग से संयोजित किया गया है ?

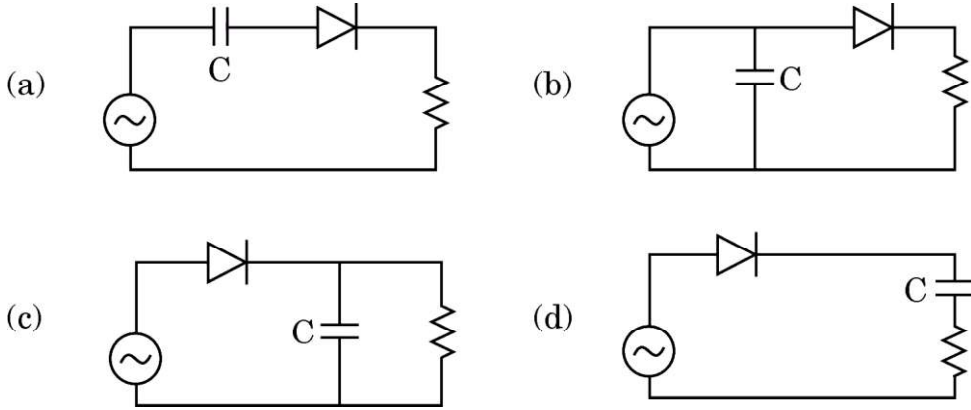

15. कोई समतल तरंग वक्रता त्रिज्या R के किसी अवतल दर्पण पर आपतन कर रही है। परावर्तित तरंग कोई गोलीय तरंग होती है जिसकी त्रिज्या होती है :

- (a) $\frac{R}{4}$ (b) $\frac{R}{2}$
(c) R (d) 2R

प्रश्न संख्या 16 से 18 अभिकथन (A) और कारण (R) प्रकार के प्रश्न हैं। दो कथन दिए गए हैं — जिनमें एक को अभिकथन (A) तथा दूसरे को कारण (R) द्वारा अंकित किया गया है। सही उत्तर नीचे दिए गए कोडों (a), (b), (c) और (d) में से चुनकर दीजिए।

- (a) अभिकथन (A) और कारण (R) दोनों सही हैं और कारण (R), अभिकथन (A) की सही व्याख्या करता है।
(b) अभिकथन (A) और कारण (R) दोनों सही हैं, परन्तु कारण (R), अभिकथन (A) की सही व्याख्या नहीं करता है।
(c) अभिकथन (A) सही है, परन्तु कारण (R) ग़लत है।
(d) अभिकथन (A) ग़लत है और कारण (R) भी ग़लत है।



13. A planar loop is rotated in a magnetic field about an axis perpendicular to the field. The polarity of induced emf changes once in each :

- (a) 1 revolution (b) $\left(\frac{1}{2}\right)$ revolution
(c) $\left(\frac{1}{4}\right)$ revolution (d) $\left(\frac{3}{4}\right)$ revolution

14. In which of the following diagrams is the capacitor 'C' connected correctly to provide smooth output of a half-wave rectifier ?

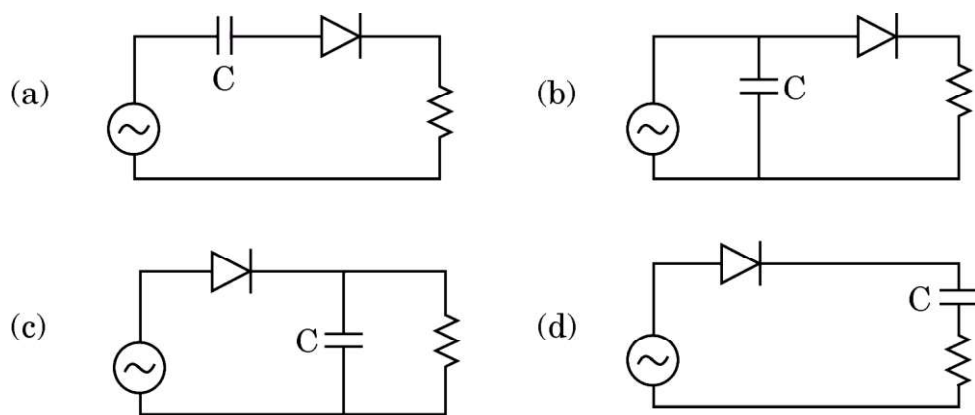

15. A plane wave is incident on a concave mirror of radius of curvature R. The reflected wave is a spherical wave of radius :

- (a) $\frac{R}{4}$ (b) $\frac{R}{2}$
(c) R (d) 2R

Questions number 16 to 18 are Assertion (A) and Reason (R) type questions. Two statements are given — one labelled Assertion (A) and the other labelled Reason (R). Select the correct answer from the codes (a), (b), (c) and (d) as given below.

- (a) Both Assertion (A) and Reason (R) are true and Reason (R) is the correct explanation of the Assertion (A).
(b) Both Assertion (A) and Reason (R) are true, but Reason (R) is **not** the correct explanation of the Assertion (A).
(c) Assertion (A) is true, but Reason (R) is false.
(d) Assertion (A) is false and Reason (R) is also false.



16. **अभिकथन (A) :** धातुओं के लिए प्रतिरोध ताप गुणांक धनात्मक और अर्धचालकों के लिए ऋणात्मक होता है ।
कारण (R) : धातुओं में आवेश वाहक ऋणावेशित होते हैं जबकि अर्धचालकों में ये धनावेशित होते हैं ।
17. **अभिकथन (A) :** समान गतिज ऊर्जा का कोई प्रोटॉन और कोई α -कण किसी एकसमान चुम्बकीय क्षेत्र में वृत्ताकार पथ पर गतिमान हैं । इनके वृत्ताकार पथों की त्रिज्याएँ समान होंगी ।
कारण (R) : किसी वृत्त में किसी आवेशित कण को गति करने के लिए आवश्यक अभिकेन्द्र बल चुम्बकीय क्षेत्र के परिमाण पर निर्भर नहीं करता है ।
18. **अभिकथन (A) :** अर्धचालक युक्तियों के निर्माण में जर्मेनियम के स्थान पर सिलिकॉन को वरीयता (प्राथमिकता) दी जाती है ।
कारण (R) : सिलिकॉन की तुलना में जर्मेनियम में ऊर्जा अन्तराल अधिक होता है ।

खण्ड ख

19. (क) निर्वात में गमन करती किसी विद्युत-चुम्बकीय तरंग के विद्युत क्षेत्र का निरूपण $E_x = E_0 \sin(kz - \omega t)$ के रूप में किया गया है । इस समीकरण में तरंग की (i) तरंगदैर्घ्य, और (ii) आवृत्ति से संबंधित प्राचलों को पहचानिए ।
(ख) किसी माध्यम में प्रकाश के वेग को निर्धारित करने वाले दो गुणधर्म लिखिए । 2
20. दो सर्वसम छड़ें, जिनमें से एक अनुचुम्बकीय पदार्थ और दूसरी प्रतिचुम्बकीय पदार्थ की है, किसी एकसमान चुम्बकीय क्षेत्र में स्थित हैं । प्रत्येक प्रकरण में चुम्बकीय क्षेत्र के पैटर्न में होने वाले आपरिवर्तनों को चित्रित करके दर्शाइए । ताप में वृद्धि होने पर इन दो पदार्थों पर क्या प्रभाव पड़ता है ? 2
21. तरंगदैर्घ्य 3500 \AA का प्रकाश दो धातुओं A और B, जिनके कार्यफलन क्रमशः 4.2 eV और 1.9 eV हैं, पर आपतन करता है । इनमें से कौन-सी धातु से प्रकाशिक-इलेक्ट्रॉन उत्पन्न होंगे ? अपने उत्तर की पुष्टि के लिए आवश्यक परिकलन कीजिए । 2



- 16.** *Assertion (A) :* The temperature coefficient of resistance is positive for metals and negative for semi-conductors.
Reason (R) : The charge carriers in metals are negatively charged whereas in semiconductors they are positively charged.
- 17.** *Assertion (A) :* A proton and an alpha particle having same kinetic energy are moving in circular paths in a uniform magnetic field. The radii of their circular paths will be equal.
Reason (R) : The centripetal force required to move a charged particle in a circle does not depend on the magnitude of the magnetic field.
- 18.** *Assertion (A) :* Silicon is preferred over germanium for making semiconductor devices.
Reason (R) : The energy gap for germanium is more than the energy gap for silicon.

SECTION B

- 19.** (a) The electric field of an electromagnetic wave passing through vacuum is represented as $E_x = E_0 \sin(kz - \omega t)$. Identify the parameter which is related to the (i) wavelength, and (ii) the frequency of the wave in the above equation.
(b) Write two properties of a medium that determine the velocity of light in that medium. 2
- 20.** Two identical bars, one of a paramagnetic material and another of a diamagnetic material are kept in a uniform magnetic field. Show diagrammatically the modifications in the pattern of magnetic field in each case. How are the two materials affected by increase in temperature? 2
- 21.** Light of wavelength 3500 \AA is incident on two metals A and B. Which of them will yield photoelectrons, if their work functions are 4.2 eV and 1.9 eV respectively? Make the necessary calculations to justify your answer. 2





22. किसी एकसमान विद्युत क्षेत्र का निरूपण $\vec{E} = (3 \times 10^3 \frac{N}{C}) \hat{i}$ के रूप में किया गया है। इस क्षेत्र के 10 cm भुजा के किसी वर्ग से गुजरने वाले वैद्युत फ्लक्स को उस स्थिति में ज्ञात कीजिए जबकि :

2

(क) इस वर्ग का तल y-z तल के समान्तर है, तथा

(ख) इस वर्ग के तल पर अभिलम्ब x-अक्ष से 60° का कोण बनाता है।

23. उच्च ऊर्जा युक्त कोई फोटॉन पुन्ज, जिसमें प्रत्येक फोटॉन की ऊर्जा E है, किसी धातु के पृष्ठ पर आपतन करता है जिससे इलेक्ट्रॉन मुक्त होते हैं। यह मानते हुए कि धातु का कार्यफलन ϕ उपेक्षणीय है, फोटॉनों की ऊर्जा E और फोटोइलेक्ट्रॉनों से संबद्ध दे ब्रॉग्ली तरंगदैर्घ्य λ के बीच संबंध ज्ञात कीजिए। E के फलन के रूप में λ के विचरण को आरेख खींचकर दर्शाइए।

2

24. (क) कोई 500 N/C का एकसमान विद्युत क्षेत्र E , +x-अक्ष के अनुदिश दिष्ट है। तीन बिन्दु O, B और A जिनके x और y निर्देशांक (cm में) क्रमशः (0, 0), (4, 0) और (0, 3) हैं, इस क्षेत्र में स्थित हैं। बिन्दुओं (i) O और A, तथा (ii) O और B के बीच विभवान्तर परिकलित कीजिए।

2

अथवा

(ख) किसी समबाहु त्रिभुज, जिसकी भुजा की लंबाई 1 m है, के शीर्षों A, B और C पर क्रमशः $1 \mu C$, $-1 \mu C$ और $2 \mu C$ के तीन बिन्दु आवेश स्थित हैं। त्रिभुज की भुजाओं AB, BC और CA के मध्य-बिन्दु क्रमशः A_1 , B_1 और C_1 हैं। इन आवेशों को A से A_1 , B से B_1 और C से C_1 तक विस्थापित करने में किया गया नेट कार्य परिकलित कीजिए।

2

25. (क) किसी प्रकाश बल्ब को कब अधिक शक्ति प्रदान की जाती है — बल्ब को जलाने के ठीक पश्चात् जब उसके फिलामेंट की चमक में वृद्धि हो रही होती है अथवा उसके पश्चात् जब उसकी चमक स्थायी हो जाती है ? क्यों ?

2

अथवा

(ख) किसी बैटरी को पहले तीन प्रतिरोधों R, 2R और 3R के श्रेणी संयोजन और फिर उनके पार्श्व संयोजन से संयोजित किया जाता है। इन दोनों प्रकरणों में तीनों प्रतिरोधों में से किसमें शक्ति क्षय अधिकतम होगा ? अपने उत्तर की पुष्टि कीजिए।

2



22. A uniform electric field is represented as $\vec{E} = (3 \times 10^3 \frac{N}{C}) \hat{i}$. Find the electric flux of this field through a square of side 10 cm when the :
- (a) plane of the square is parallel to y-z plane, and
 - (b) the normal to plane of the square makes an angle of 60° with the x-axis.

2

23. A beam of high energy photons, each of energy of E is incident on a metal surface and electrons are ejected from the surface. Assuming that the work function of the metal, ϕ is negligible, find the relation between the de Broglie wavelength λ associated with photoelectrons and the energy of photons E. Show in a figure, the variation of λ as a function of E.

2

24. (a) A uniform electric field E of 500 N/C is directed along +x axis. O, B and A are three points in the field having x and y coordinates (in cm) (0, 0), (4, 0) and (0, 3) respectively. Calculate the potential difference between the points (i) O and A, and (ii) O and B.

2

OR

- (b) Three point charges $1 \mu\text{C}$, $-1 \mu\text{C}$ and $2 \mu\text{C}$ are kept at the vertices A, B and C respectively of an equilateral triangle of side 1 m. A_1 , B_1 and C_1 are the midpoints of the sides AB, BC and CA respectively. Calculate the net amount of work done in displacing the charge from A to A_1 , from B to B_1 and from C to C_1 .

2

25. (a) When is more power delivered to a light bulb — just after it is turned on and the glow of the filament is increasing or after the glow becomes steady ? Why ?

2

OR

- (b) A battery is connected first across the series combination and then across the parallel combination, of three resistances R, 2R and 3R. In which of the three resistances will power dissipated be maximum in the two cases ? Justify your answer.

2





खण्ड ग

26. पृष्ठ के भीतर की ओर दिष्ट किसी एकसमान चुम्बकीय क्षेत्र \vec{B} में कोई आयताकार चालक PQRS, जिसकी भुजा PQ चलायमान है, आरेख में दर्शाए अनुसार स्थित है।

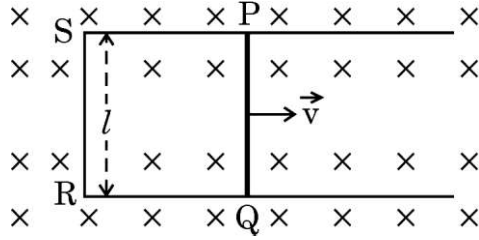

- (क) PQ को वेग \vec{v} से दाईं ओर गतिमान कराया गया है। PQ के सिरों पर विकसित वि.वा. बल (emf) के लिए व्यंजक प्राप्त कीजिए।
- (ख) यदि PQRS का प्रतिरोध r है, तो PQ को किसी नियत वेग \vec{v} से गति कराने के लिए आवश्यक बल ज्ञात कीजिए।

3

27. (क) (i) किसी हाइड्रोजन परमाणु में कोई इलेक्ट्रॉन द्वितीय उत्तेजित अवस्था से प्रथम उत्तेजित अवस्था में कूदान करता है। हाइड्रोजन परमाणु के स्पेक्ट्रम की उस स्पेक्ट्रमी श्रेणी का नाम लिखिए जिसमें उत्सर्जित विकिरण पाया जा सकता है।
- (ii) हाइड्रोजन स्पेक्ट्रम की बामर श्रेणी और पाशन श्रेणी की “सर्वाधिक ऊर्ज स्पेक्ट्रमी” रेखाओं की तरंगदैर्घ्यों का अनुपात ज्ञात कीजिए।

3

अथवा

- (ख) (i) गतिज ऊर्जा K का कोई α -कण परमाणु क्रमांक Z के किसी नाभिक का उपगमन कर रहा है। यह नाभिक के बहुत निकट पहुँचता है और फिर किसी दूरी (d) पर उपगमन करके अपनी दिशा उत्क्रमित करता है। α -कण की गतिज ऊर्जा के पदों में उपगमन की निकटतम दूरी (d) के लिए व्यंजक प्राप्त कीजिए।
- (ii) कोई प्रोटॉन और कोई α -कण समान वेगों से किसी लक्ष्य नाभिक की ओर आमने-सामने की स्थिति में उपगमन करते हैं। इनकी लक्ष्य नाभिक की उपगमन की निकटतम दूरियों का अनुपात ज्ञात कीजिए।

3





SECTION C

26. The figure shows a rectangular conductor PQRS with a movable arm PQ, kept in a uniform magnetic field \vec{B} pointing into the page.

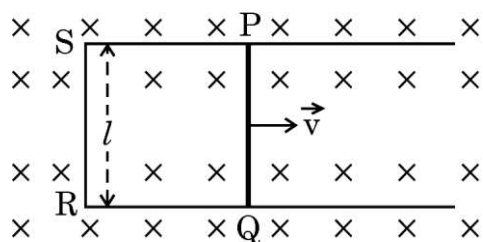

- (i) PQ is moved towards the right with a velocity \vec{v} . Obtain the expression for the emf developed across PQ.
- (ii) If r is the resistance of PQRS, find the force required to move PQ with constant velocity \vec{v} . 3
27. (a) (i) An electron in a hydrogen atom jumps from second excited state to the first excited state. Name the spectral series in the spectrum of hydrogen atom to which the emitted radiation belongs.
- (ii) Find the ratio of the wavelengths of the “most energetic spectral” lines in the Balmer series to that in Paschen series of Hydrogen spectrum. 3

OR

- (b) (i) An α -particle having kinetic energy K approaches a nucleus of atomic number Z . It gets close to the nucleus and then approaches a distance (d) and reverses its direction. Obtain an expression for the distance of closest approach (d) in terms of kinetic energy of the α -particle.
- (ii) A proton and an alpha particle approach a target nucleus in head-on position, with equal velocities. Find the ratio of their distances of closest approach to the target nucleus. 3





28. (क) (i) किस प्रकरण में विवर्तन प्रभाव अधिक प्रबल होता है — जब झिरी को दो ब्लेडों से बनाया जाता है अथवा जब झिरी को दो अंगुलियों से बनाया जाता है ?
- (ii) पीले प्रकाश ($\lambda = 6000 \text{ \AA}$) से $1 \times 10^{-4} \text{ m}$ चौड़ाई की किसी एकल झिरी को प्रदीप्त किया गया है। (i) झिरी से 1.5 m दूरी पर स्थित पर्दे पर विवर्तन पैटर्न का प्रेक्षण करने पर केन्द्रीय उच्चिष्ठ के दोनों ओर की दो काली लाइनों के बीच की दूरी, तथा (ii) प्रथम निम्निष्ठ का कोणीय विस्तार परिकलित कीजिए।

3

अथवा

- (ख) (i) यदि एकवर्णी प्रकाश स्रोत को श्वेत प्रकाश स्रोत से प्रतिस्थापित कर दिया जाए, तो यंग के द्विझिरी प्रयोग में केन्द्रीय चमकीली फ्रिंज का वर्ण (रंग) क्या होगा ? अपने उत्तर के लिए कारण दीजिए।
- (ii) यंग के किसी द्विझिरी प्रयोग में, झिरियों के बीच का पृथकन 0.3 mm तथा पर्दे की झिरियों से दूरी 1.5 m है। केन्द्रीय चमकीली फ्रिंज और छठी चमकीली फ्रिंज के बीच की दूरी 1.8 cm है। प्रयोग में उपयोग किए गए प्रकाश की तरंगदैर्घ्य ज्ञात कीजिए।

3

29. (क) किसी गैल्वेनोमीटर को सीधे ही विद्युत धारा मापने के लिए उपयोग करने की सलाह क्यों नहीं दी जानी चाहिए ?
- (ख) गैल्वेनोमीटर के पार्श्व में संयोजित किए जाने वाले प्रतिरोध का मान निम्न क्यों होना चाहिए ?
- (ग) क्या किसी परिपथ में ऐमीटर द्वारा दर्शाया जाने वाला पाठ्यांक परिपथ में प्रवाहित वास्तविक धारा से कम अथवा अधिक होता है ? क्यों ?

3

30. कारण सहित निम्नलिखित प्रश्नों के उत्तर दीजिए :

3

- (क) प्रेरित वि.वा. बल (emf) से सदैव ही प्रेरित धारा उत्पन्न नहीं होती है।
- (ख) किसी प्रबल चुम्बक के ध्रुवों के बीच दोलन करते समय कॉपर की किसी पट्टिका की गति मंदित हो जाती है।
- (ग) किसी परिशुद्ध प्रेरक वाले ac परिपथ में शक्ति का कोई उपभोग नहीं होता है।





28. (a) (i) In which case is diffraction effect more dominant — slit formed by 2 blades or slit formed by two fingers ?
- (ii) Yellow light ($\lambda = 6000 \text{ \AA}$) illuminates a single slit of width $1 \times 10^{-4} \text{ m}$. Calculate (i) the distance between two dark lines on either side of central maximum, in the diffraction pattern observed on a screen kept 1.5 m away from the slit, and (ii) the angular spread of the first minimum. 3

OR

- (b) (i) What will be the colour of the central bright fringe in Young's double slit experiment if the monochromatic source is replaced by a source of white light ? Give reason for your answer.
- (ii) In Young's double slit experiment, the slits are separated by 0.3 mm and the screen is placed 1.5 m away from the slits. The distance between the central bright fringe and the sixth bright fringe is found to be 1.8 cm. Find the wavelength of light used in the experiment. 3
29. (a) It is not advisable to use a galvanometer as such to measure current directly. Why ?
- (b) Why should the value of resistance connected in parallel to a galvanometer be low ?
- (c) Is the reading shown by an ammeter in a circuit less than or more than the actual value of current flowing in the circuit ? Why ? 3
30. Answer the following, giving reasons : 3
- (a) Induced emf does not always produce induced current.
- (b) The motion of a copper plate is damped when it is allowed to oscillate between pole pieces of a strong magnet.
- (c) No power is consumed in an ac circuit containing a pure inductor.





खण्ड घ

31. (क) (i) चालन विधा में किसी p-n संधि डायोड के I – V अभिलाक्षणिक का अध्ययन करने के लिए परिपथ आरेख खींचिए । ग्राफ पर इस डायोड की देहली वोल्टता अंकित कीजिए । इस वोल्टता के महत्त्व की व्याख्या कीजिए ।
- (ii) आरेख में दर्शाए गए परिपथ में डायोड के सिरो पर अग्र वोल्टता पात 0.3 V है । A और B के बीच वोल्टता-अन्तर ज्ञात कीजिए ।

5

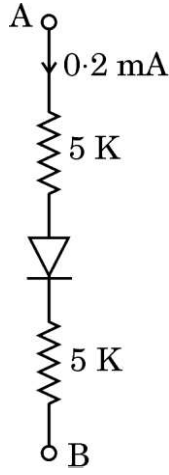

अथवा

- (ख) (i) ऊर्जा-स्तर आरेखों के आधार पर ठोसों के धातुओं, रोधियों और अर्धचालकों में वर्गीकरण का संक्षेप में वर्णन कीजिए ।
- (ii) किसी सिलिकॉन डायोड में, वोल्टता 0.6 V से 0.7 V परिवर्तित होने पर धारा 10 mA से बढ़कर 20 mA हो जाती है । इस डायोड का गतिक प्रतिरोध परिकलित कीजिए ।

5

32. (क) (i) किसी चालक में विद्युत धारा और मुक्त इलेक्ट्रॉनों के अपवाह वेग के बीच संबंध व्युत्पन्न कीजिए । ताप में वृद्धि के साथ किसी चालक के प्रतिरोध में विचरण की संक्षेप में व्याख्या कीजिए ।
- (ii) किसी अज्ञात प्रतिरोध से श्रेणी में संयोजित कोई ऐमीटर दो सर्वसम बैटरियों, जिनमें प्रत्येक का वि.वा. बल (emf) 1.5 V है, के (i) श्रेणी संयोजन, और (ii) पार्श्व संयोजन के सिरो से संयोजित है । यदि इन दोनों प्रकरणों में रिकॉर्ड की गयी धाराएँ क्रमशः $\left(\frac{1}{2}\right)$ A और $\left(\frac{1}{3}\right)$ A हैं, तो प्रत्येक बैटरी का आन्तरिक प्रतिरोध परिकलित कीजिए ।

5

अथवा





SECTION D

31. (a) (i) Draw the circuit diagram used to study I – V characteristics of a p-n junction diode in conducting mode. Mark on the graph the threshold voltage of the diode. Explain the significance of this voltage.
- (ii) In the circuit shown in the figure, the forward voltage drop across the diode is 0.3 V. Find the voltage difference between A and B.

5

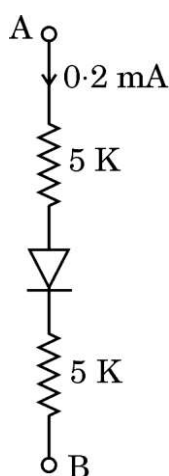

OR

- (b) (i) Briefly describe the classification of solids into metals, insulators and semi-conductors on the basis of energy level diagrams.
- (ii) In a silicon diode, the current increases from 10 mA to 20 mA when the voltage changes from 0.6 V to 0.7 V. Calculate the dynamic resistance of the diode.
32. (a) (i) Derive the relation between the current and the drift velocity of free electrons in a conductor. Briefly explain the variation of resistance of a conductor with rise in temperature.
- (ii) An ammeter, together with an unknown resistance in series is connected across two identical batteries, each of emf 1.5 V, connected (i) in series, and (ii) in parallel. If the current recorded in the two cases be $\left(\frac{1}{2}\right)$ A and $\left(\frac{1}{3}\right)$ A respectively, calculate the internal resistance of each battery.

5

5

OR





- (ख) (i) किरखोफ के नियम लिखिए । इन नियमों का उपयोग करके व्हीटस्टोन सेतु के संतुलन के लिए शर्त प्राप्त कीजिए ।
- (ii) किरखोफ के नियम का उपयोग करके आरेख में दर्शाए गए परिपथ की शाखाओं MN, TO और SP से प्रवाहित धाराएँ निर्धारित कीजिए ।

5

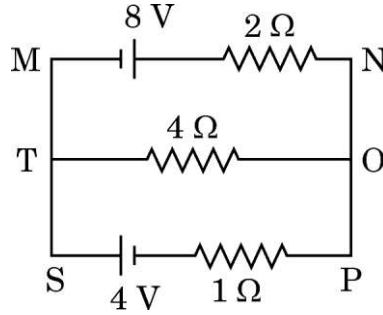

33. (क) (i) किसी अवतल दर्पण द्वारा किसी बिम्ब का प्रतिबिम्ब बनना दर्शाने के लिए किरण आरेख खींचिए जबकि बिम्ब दर्पण के f और $2f$ के बीच स्थित है । इस आरेख का उपयोग करके दर्पण समीकरण व्युत्पन्न कीजिए ।
- (ii) कोई बिम्ब 12 cm फोकस दूरी के किसी उत्तल दर्पण के सामने 30 cm दूरी पर स्थित है । बनने वाले प्रतिबिम्ब की प्रकृति और स्थिति ज्ञात कीजिए ।

5

अथवा

- (ख) (i) किसी संयुक्त सूक्ष्मदर्शी द्वारा प्रतिबिम्ब बनना दर्शाने के लिए किरण आरेख खींचिए । इस प्रकार इसके कुल आवर्धन के लिए उस स्थिति में व्यंजक प्राप्त कीजिए जबकि अंतिम प्रतिबिम्ब स्पष्ट दर्शन की न्यूनतम दूरी पर बनता है ।
- (ii) किसी संयुक्त सूक्ष्मदर्शी के अभिदृश्यक की फोकस दूरी 2.0 cm और नेत्रिका की फोकस दूरी 6.0 cm है । यदि इन दोनों लेंसों के बीच पृथकन 24 cm है, तो उस स्थिति में कुल आवर्धन ज्ञात कीजिए जब अंतिम प्रतिबिम्ब अनंत पर बनता है ।

5





- (b) (i) State Kirchhoff's rules. Use them to obtain the condition of balance for a Wheatstone Bridge.
- (ii) Use Kirchhoff's rule to determine the currents flowing through the branches MN, TO and SP in the circuit shown in the figure.

5

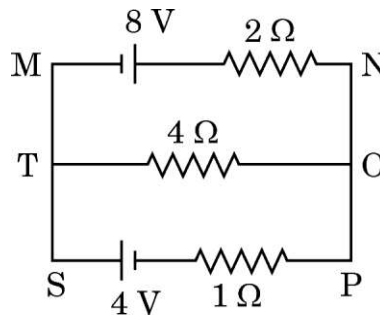

33. (a) (i) Draw a ray diagram to show the formation of image by a concave mirror when the object is placed between f and $2f$. Using this diagram, derive the mirror equation.
- (ii) An object is kept 30 cm in front of a convex mirror of focal length 12 cm. Find the nature and position of the image formed.

5

OR

- (b) (i) Draw a ray diagram showing the image formation by a compound microscope. Hence obtain the expression for total magnification when the image is formed at least distance of distinct vision.
- (ii) A compound microscope consists of an objective lens of focal length 2.0 cm and an eyepiece of focal length 6.0 cm. If they are separated by a distance of 24 cm, find the total magnification when the image is formed at infinity.

5





खण्ड ड

34.

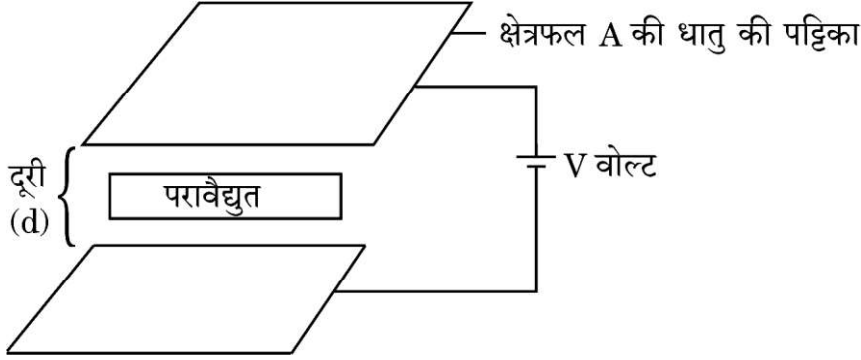

कोई समान्तर पट्टिका संधारित्र एक ऐसी व्यवस्था है जिसमें सर्वसम धातु की दो पट्टिकाओं को एक दूसरे से किसी लघु दूरी पर समान्तर रखा जाता है। किसी संधारित्र की धारिता दो पट्टिकाओं के साइज़ और उनके पृथकन पर तथा पट्टिकाओं के बीच रखे माध्यम के परावैद्युतांक पर भी निर्भर करती है। प्रतिरोधकों की भाँति संधारित्रों को भी श्रेणी अथवा पार्श्व अथवा दोनों के संयोजन में व्यवस्थित किया जा सकता है। पट्टिकाओं के बीच विद्युत क्षेत्र होने से आवेशित संधारित्र ऊर्जा संचित करते हैं।

(क) किसी समान्तर पट्टिका संधारित्र की पट्टिकाओं के बीच किसी परावैद्युत पदार्थ (माध्यम) को रखने पर उसकी धारिता $10 \mu\text{F}$ से बढ़कर $80 \mu\text{F}$ हो जाती है। इस माध्यम का परावैद्युतांक ज्ञात कीजिए।

1

(ख) n संधारित्र, जिनमें प्रत्येक की धारिता C है, श्रेणी में संयोजित हैं। इस संयोजन की तुल्य धारिता ज्ञात कीजिए।

1

(ग) किसी संधारित्र को किसी बैटरी से संयोजित करके विभव (V) तक आवेशित किया गया है। कुछ समय बाद, बैटरी को वियोजित करके पट्टिकाओं के बीच कोई परावैद्युत रख दिया जाता है। पट्टिकाओं के बीच विभवान्तर और संधारित्र में संचित ऊर्जा पर क्या प्रभाव होगा? अपने उत्तर की पुष्टि कीजिए।

2

अथवा





SECTION E

34.

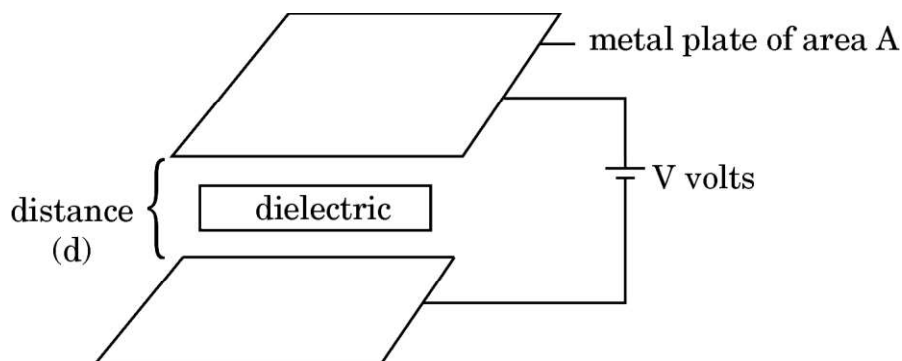

A parallel plate capacitor is an arrangement of two identical metal plates kept parallel, a small distance apart. The capacitance of a capacitor depends on the size and separation of the two plates and also on the dielectric constant of the medium between the plates. Like resistors, capacitors can also be arranged in series or parallel or a combination of both. By virtue of electric field between the plates, charged capacitors store energy.

- (a) The capacitance of a parallel plate capacitor increases from $10 \mu\text{F}$ to $80 \mu\text{F}$ on introducing a dielectric medium between the plates. Find the dielectric constant of the medium. 1
- (b) n capacitors, each of capacitance C , are connected in series. Find the equivalent capacitance of the combination. 1
- (c) A capacitor is charged to a potential (V) by connecting it to a battery. After some time, the battery is disconnected and a dielectric is introduced between the plates. How will the potential difference between the plates, and the energy stored in it be affected? Justify your answer. 2

OR





- (ग) यदि प्रत्येक संधारित्र की धारिता C है, तो बिन्दुओं A और B के बीच तुल्य धारिता ज्ञात कीजिए ।

2

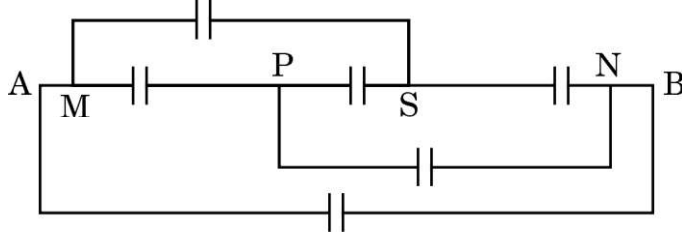

35. कोई प्रिज़्म त्रिभुजाकार आधार व शीर्ष का तीन आयताकार फलकों से घिरा पारदर्शी पदार्थ का ठोस माध्यम होता है । इसके किसी एक फलक पर आपतन कोण i पर आपतित प्रकाश किरण प्रिज़्म से गुज़रने पर दो बार अपवर्तित होती है । इस प्रकार यह अपने मूल पथ से किसी कोण δ पर विचलित हो जाती है । कोण i के किसी निश्चित मान के लिए विचलन कोण न्यूनतम ($\delta = \delta_m$) हो जाता है । इस स्थिति में, प्रिज़्म के भीतर अपवर्तित किरण उसके आधार के समान्तर गमन करती है । कोण A और कोण δ_m के पदों में प्रिज़्म के पदार्थ के अपवर्तनांक μ के लिए कोई व्यंजक प्राप्त किया जा सकता है ।

- (क) आपतन कोण i के साथ विचलन कोण δ के विचरण को आरेख खींचकर दर्शाइए । 1
- (ख) यह दर्शाइए की लघु प्रिज़्म कोण A के लिए प्रिज़्म के पदार्थ के अपवर्तनांक μ को $\mu = 1 + \frac{\delta_m}{A}$ के रूप में लिखा जा सकता है । 1
- (ग) कोई प्रकाश किरण किसी समबाहु प्रिज़्म से इस प्रकार गुज़रती है कि आपतन कोण और निर्गत कोण दोनों ही प्रिज़्म कोण A के बराबर हैं । प्रिज़्म के पदार्थ का अपवर्तनांक A के पदों में ज्ञात कीजिए । 2

अथवा

- (ग) आरेख में दर्शाए अनुसार कोई प्रकाश किरण किसी प्रिज़्म, जिसका प्रिज़्म कोण 75° है, से गुज़रती है । प्रतिवेश के सापेक्ष प्रिज़्म के पदार्थ का अपवर्तनांक $\sqrt{2}$ है । आपतन कोण i ज्ञात कीजिए । 2

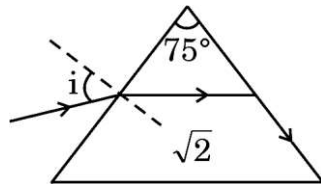



- (c) Find the equivalent capacitance between points A and B, if capacitance of each capacitor is C. 2

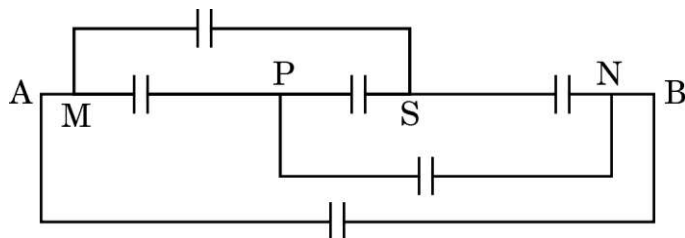

35. A prism is a solid transparent medium bounded by three rectangular faces with triangular base and top. A ray of light incident at angle i on one face of a prism suffers two refractions on passing through a prism. Hence it deviates through a certain angle δ from its original path. The angle of deviation becomes minimum ($\delta = \delta_m$) for a certain value of angle i . In such a condition, the refracted ray inside the prism becomes parallel to its base. An expression for refractive index μ of the material of the prism can be obtained in terms of angle A and angle δ_m .

- (a) Show in a figure the variation of angle δ with angle of incidence i . 1
- (b) Show that for a prism of small angle A, the refractive index μ of its material can be written as $\mu = 1 + \frac{\delta_m}{A}$. 1
- (c) A ray of light passes through an equilateral prism such that both the angle of incidence and the angle of emergence are equal to the angle of prism A. Find the refractive index of the material of the prism, in terms of A. 2

OR

- (c) A ray of light passes through a prism of angle 75° , as shown in the figure. The refractive index of the material of the prism, with respect to its surrounding is $\sqrt{2}$. Find the angle of incidence i . 2

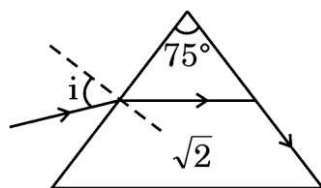

Marking Scheme Strictly Confidential (For Internal and Restricted use only) Senior Secondary School Supplementary Examination, July- 2023 SUBJECT NAME: PHYSICS SUBJECT CODE: 042 PAPER CODE : 55/C/3	
<u>General Instructions: -</u>	
1	You are aware that evaluation is the most important process in the actual and correct assessment of the candidates. A small mistake in evaluation may lead to serious problems which may affect the future of the candidates, education system and teaching profession. To avoid mistakes, it is requested that before starting evaluation, you must read and understand the spot evaluation guidelines carefully.
2	“Evaluation policy is a confidential policy as it is related to the confidentiality of the examinations conducted, Evaluation done and several other aspects. Its’ leakage to public in any manner could lead to derailment of the examination system and affect the life and future of millions of candidates. Sharing this policy/document to anyone, publishing in any magazine and printing in News Paper/Website etc may invite action under various rules of the Board and IPC.”
3	Evaluation is to be done as per instructions provided in the Marking Scheme. It should not be done according to one’s own interpretation or any other consideration. Marking Scheme should be strictly adhered to and religiously followed. However, while evaluating, answers which are based on latest information or knowledge and/or are innovative, they may be assessed for their correctness otherwise and due marks be awarded to them. In class-XII, while evaluating two competency-based questions, please try to understand given answer and even if reply is not from marking scheme but correct competency is enumerated by the candidate, due marks should be awarded.
4	The Marking scheme carries only suggested value points for the answers. These are in the nature of Guidelines only and do not constitute the complete answer. The students can have their own expression and if the expression is correct, the due marks should be awarded accordingly.
5	The Head-Examiner must go through the first five answer books evaluated by each evaluator on the first day, to ensure that evaluation has been carried out as per the instructions given in the Marking Scheme. If there is any variation, the same should be zero after deliberation and discussion. The remaining answer books meant for evaluation shall be given only after ensuring that there is no significant variation in the marking of individual evaluators.
6	Evaluators will mark(✓) wherever answer is correct. For wrong answer CROSS ‘X’ be marked. Evaluators will not put right (✓) while evaluating which gives an impression that answer is correct and no marks are awarded. This is most common mistake which evaluators are committing.
7	If a question has parts, please award marks on the right-hand side for each part. Marks awarded for different parts of the question should then be totaled up and written in the left-hand margin and encircled. This may be followed strictly.
8	If a question does not have any parts, marks must be awarded in the left-hand margin and encircled. This may also be followed strictly.
9	If a student has attempted an extra question, answer of the question deserving more marks should be retained and the other answer scored out with a note “Extra Question” .
10	No marks to be deducted for the cumulative effect of an error. It should be penalized only once.
11	A full scale of marks 70 has to be used. Please do not hesitate to award full marks if the answer deserves it.
12	Every examiner has to necessarily do evaluation work for full working hours i.e., 8 hours

	every day and evaluate 20 answer books per day in main subjects and 25 answer books per day in other subjects (Details are given in Spot Guidelines).
13	<p>Ensure that you do not make the following common types of errors committed by the Examiner in the past:- Giving more marks for an answer than assigned to it.</p> <ul style="list-style-type: none"> ● Wrong totaling of marks awarded on an answer. ● Wrong transfer of marks from the inside pages of the answer book to the title page. <p>Wrong question wise totaling on the title page.</p> <ul style="list-style-type: none"> ● Leaving answer or part thereof unassessed in an answer book. ● ● Wrong totaling of marks of the two columns on the title page. ● Wrong grand total. ● Marks in words and figures not tallying/not same. ● Wrong transfer of marks from the answer book to online award list. ● Answers marked as correct, but marks not awarded. (Ensure that the right tick mark is correctly and clearly indicated. It should merely be a line. Same is with the X for incorrect answer.) ● Half or a part of answer marked correct and the rest as wrong, but no marks awarded.
14	While evaluating the answer books if the answer is found to be totally incorrect, it should be marked as cross (X) and awarded zero (0)Marks.
15	Any un assessed portion, non-carrying over of marks to the title page, or totaling error detected by the candidate shall damage the prestige of all the personnel engaged in the evaluation work as also of the Board. Hence, in order to uphold the prestige of all concerned, it is again reiterated that the instructions be followed meticulously and judiciously.
16	The Examiners should acquaint themselves with the guidelines given in the “ Guidelines for spot Evaluation ” before starting the actual evaluation.
17	Every Examiner shall also ensure that all the answers are evaluated, marks carried over to the title page, correctly totaled and written in figures and words.
18	The candidates are entitled to obtain photocopy of the Answer Book on request on payment of the prescribed processing fee. All Examiners/Additional Head Examiners/Head Examiners are once again reminded that they must ensure that evaluation is carried out strictly as per value points for each answer as given in the Marking Scheme.



MARKING SCHEME: PHYSICS(042)

Code:

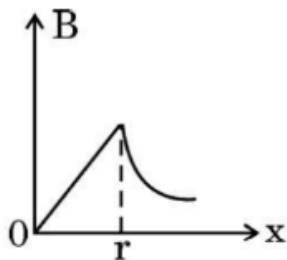
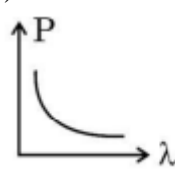
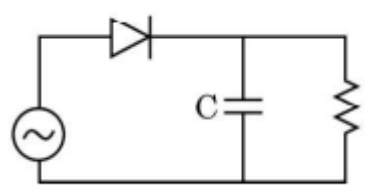
Q.No.	VALUE POINTS/EXPECTED ANSWERS	Marks	Total Marks
1.	(b) $p_0(E_2 + E_1) k$	1	1
2.	(a) 	1	1
3.	(b) m and M/2	1	1
4.	(d) first decreases to become zero and then increases	1	1
5.	(d) x- rays	1	1
6.	(b) $\frac{I_0}{2}$	1	1
7.	(b) 	1	1
8.	(d) Both for the light nuclei and heavy nuclei.	1	1
9.	(a) increase	1	1
10.	(d) The voltage shown in V_1 lags behind in phase with the voltage shown in V_2 .	1	1
11.	(b) 1:1	1	1
12.	(a) 0°	1	1
13.	(b) $(\frac{1}{2})$ revolution	1	1
14.	(c) 	1	1
15.	(b) $\frac{R}{2}$	1	1
16.	(c) Assertion (A) is true, but Reason (R) is false.	1	1
17.	(d) Assertion (A) is false and Reason (R) is also false.	1	1
18.	(c) Assertion (A) is true, but Reason (R) is false.	1	1

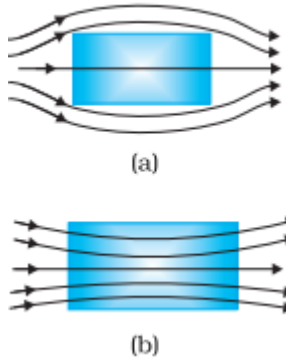
SECTION -B			
19.	<div style="border: 1px solid black; padding: 5px; margin-bottom: 10px;"> (a) Identification of parameters $\frac{1}{2} + \frac{1}{2}$ (b) Two properties of medium $\frac{1}{2} + \frac{1}{2}$ </div> <p>(a) Parameter relating wavelength is 'k' ($= \frac{2\pi}{\lambda}$) Parameter relating frequency is 'ω' ($= 2\pi\nu$)</p> <p>(b) 1. Electric properties of the medium 2. Magnetic properties of the medium</p> <p>Alternatively: i. Permittivity (ϵ) of the medium ii. Permeability (μ) of the medium</p>	$\frac{1}{2}$ $\frac{1}{2}$ $\frac{1}{2}$ $\frac{1}{2}$	2
20.	<div style="border: 1px solid black; padding: 5px; margin-bottom: 10px;"> Showing the modifications in the pattern of magnetic field $\frac{1}{2} + \frac{1}{2}$ Effect of increase in temperature $\frac{1}{2} + \frac{1}{2}$ </div> <div style="text-align: center;">  <p>(a)</p> <p>(b)</p> </div> <p>No effect in case of diamagnetic materials. Magnetization/ magnetic susceptibility decrease in case of paramagnetic materials.</p>	$\frac{1}{2} + \frac{1}{2}$ $\frac{1}{2}$ $\frac{1}{2}$	2
21.	<div style="border: 1px solid black; padding: 5px; margin-bottom: 10px;"> Calculation of energy of incident light in 'eV' 1 Conclusion with justification $\frac{1}{2} + \frac{1}{2}$ </div> $E = \frac{\lambda c}{\lambda}$ $= \frac{6.63 \times 10^{-34} \times 3 \times 10^8}{3500 \times 10^{-10} \times 1.6 \times 10^{-19}} eV$ $E = 3.55 eV$ <p>Metal B Since energy of incident light is more than the work function of metal 'B'.</p>	$\frac{1}{2}$ $\frac{1}{2}$ $\frac{1}{2}$ $\frac{1}{2}$	

	(Note: Give full credit of one mark if student writes 'Metal B' only.)		2
22.	<div style="border: 1px solid black; padding: 5px; margin-bottom: 10px;"> (a) Calculation of electric flux $\frac{1}{2} + \frac{1}{2}$ (b) Calculation of electric flux $\frac{1}{2} + \frac{1}{2}$ </div> (a) $\Phi = \vec{E}A\hat{i} = EA$ $= 3 \times 10^3 \times (100 \times 10^{-4})$ $= 30NC^{-1}m^2$ (b) $\Phi = EA \cos 60^\circ$ $= 15NC^{-1}m^2$	$\frac{1}{2}$ $\frac{1}{2}$ $\frac{1}{2}$ $\frac{1}{2}$	
23.	<div style="border: 1px solid black; padding: 5px; margin-bottom: 10px;"> Einstein's photoelectric equation $\frac{1}{2}$ Relation between momentum and kinetic energy $\frac{1}{2}$ de- Broglie relation $\frac{1}{2}$ Relation between λ and E $\frac{1}{2}$ </div> $h\nu = \Phi_o + E_v^{\max}$ As Φ_o is negligible $E_v^{\max} = h\nu$ $E = h\nu$ $E = \frac{p^2}{2m}$ $p = \sqrt{2mE}$ $\lambda = \frac{h}{p}$ $\lambda = \frac{h}{\sqrt{2mE}}$	$\frac{1}{2}$ $\frac{1}{2}$ $\frac{1}{2}$ $\frac{1}{2}$	2
24.	<div style="border: 1px solid black; padding: 5px; margin-bottom: 10px;"> (i) Calculation of V_{OA} $\frac{1}{2} + \frac{1}{2}$ (ii) Calculation of V_{OB} $\frac{1}{2} + \frac{1}{2}$ </div> (a) (i) $V_{OA} = E(x_2 - x_1)$ $V_{OA} = 500 \times 0 = 0 \text{ volt}$ (ii) $V_{OB} = -E(x_2 - x_1)$ $V_{OB} = -500 \times (4 \times 10^{-2})$ $= -20 \text{ V}$ OR	$\frac{1}{2}$ $\frac{1}{2}$ $\frac{1}{2}$ $\frac{1}{2}$	



	<table border="1" style="width: 100%; border-collapse: collapse;"> <tr> <td style="padding: 2px;">Calculating of initial potential energy</td> <td style="text-align: right; padding: 2px;">1</td> </tr> <tr> <td style="padding: 2px;">Calculation of final potential energy</td> <td style="text-align: right; padding: 2px;">1/2</td> </tr> <tr> <td style="padding: 2px;">Calculation of net work done</td> <td style="text-align: right; padding: 2px;">1/2</td> </tr> </table> <p>Initial electrostatic potential energy of the system</p> $U_i = \frac{k}{r} [1 \times (-1) + (-1) \times 2 + (1) \times (2)] \times 10^{-12}$ $= \frac{9 \times 10^9}{1} [-1 - 2 + 2] \times 10^{-12}$ $= -9 \times 10^{-3} J$ <p>Now $A_1B_1 = B_1C_1 = A_1C_1 = \frac{1}{2} m$</p> <p>Final electrostatic potential energy of the system</p> $U_f = \frac{-9 \times 10^{-9}}{1/2} = -18 \times 10^{-3} J$ <p>Amount of work done $W = U_f - U_i$</p> $W = -18 \times 10^{-3} + 9 \times 10^{-3} = -9 \times 10^{-3} J$	Calculating of initial potential energy	1	Calculation of final potential energy	1/2	Calculation of net work done	1/2	1 1/2 1/2	2						
Calculating of initial potential energy	1														
Calculation of final potential energy	1/2														
Calculation of net work done	1/2														
25.	<table border="1" style="width: 100%; border-collapse: collapse;"> <tr> <td style="padding: 2px;">(a) For Answer</td> <td style="text-align: right; padding: 2px;">1</td> </tr> <tr> <td style="padding: 2px;">Reason</td> <td style="text-align: right; padding: 2px;">1</td> </tr> </table> <p>(a) Power delivered just after it is turned on, will be more because resistance of the bulb is low. After some time temperature of the bulb increases and resistance also increases and therefore power $\left(\frac{V^2}{R}\right)$ becomes low.</p> <p style="text-align: center;">OR</p> <table border="1" style="width: 100%; border-collapse: collapse;"> <tr> <td style="padding: 2px;">For series Answer</td> <td style="text-align: right; padding: 2px;">1/2</td> </tr> <tr> <td style="padding: 2px;">Justification</td> <td style="text-align: right; padding: 2px;">1/2</td> </tr> <tr> <td style="padding: 2px;">For parallel Answer</td> <td style="text-align: right; padding: 2px;">1/2</td> </tr> <tr> <td style="padding: 2px;">Justification</td> <td style="text-align: right; padding: 2px;">1/2</td> </tr> </table> <p>For series Power dissipated will be maximum for 3R. Because current is same and power is proportional to resistance.</p> <p>For parallel Power dissipated will be maximum for R. Because voltage is same and power is inversely proportional to resistance.</p>	(a) For Answer	1	Reason	1	For series Answer	1/2	Justification	1/2	For parallel Answer	1/2	Justification	1/2	1 1 1/2 1/2 1/2 1/2	2
(a) For Answer	1														
Reason	1														
For series Answer	1/2														
Justification	1/2														
For parallel Answer	1/2														
Justification	1/2														
	SECTION-C														



26.	<table border="1" style="width: 100%; border-collapse: collapse;"> <tbody> <tr> <td style="width: 50%;">(i) Obtaining the expression for e.m.f.</td> <td style="width: 50%; text-align: right;">1 ½</td> </tr> <tr> <td>(ii) Finding the force required</td> <td style="text-align: right;">1 ½</td> </tr> </tbody> </table> <p>(i) $\phi_B = Blx$ $\varepsilon = -\frac{d\phi_B}{dt}$ $= -\frac{d}{dt}(Blx)$ $= -Bl\frac{dx}{dt}$ $\varepsilon = -Blv$</p> <p>(ii) $i = \frac{\varepsilon}{r}$ $\vec{F} = i(\vec{l} \times \vec{B})$ $F = \frac{\varepsilon}{r} iB = \frac{Blv}{r}(lB)$ $F = \frac{B^2 l^2 v}{r}$</p>	(i) Obtaining the expression for e.m.f.	1 ½	(ii) Finding the force required	1 ½	½ ½ ½ ½ ½	3								
(i) Obtaining the expression for e.m.f.	1 ½														
(ii) Finding the force required	1 ½														
27.	<table border="1" style="width: 100%; border-collapse: collapse;"> <tbody> <tr> <td style="width: 50%;">(a) (i) Name of spectral series</td> <td style="width: 50%; text-align: right;">½</td> </tr> <tr> <td>(ii) Calculation of λ_B</td> <td style="text-align: right;">½ + ½</td> </tr> <tr> <td>Calculation of λ_p</td> <td style="text-align: right;">½ + ½</td> </tr> <tr> <td>Calculation of ratio</td> <td style="text-align: right;">½</td> </tr> </tbody> </table> <p>(a) (i) Balmer series (ii) $\frac{1}{\lambda_B} = R\left[\frac{1}{2^2} - \frac{1}{\infty}\right]$ $\frac{1}{\lambda_B} = \frac{R}{4}$ $\frac{1}{\lambda_p} = R\left[\frac{1}{3^2} - \frac{1}{\infty}\right]$ $\frac{1}{\lambda_p} = \frac{R}{9}$ $\frac{\lambda_B}{\lambda_p} = \frac{4}{9}$</p> <p style="text-align: center;">OR</p> <table border="1" style="width: 100%; border-collapse: collapse;"> <tbody> <tr> <td style="width: 50%;">(b) (i) Obtaining expression for distance of closest approach</td> <td style="width: 50%; text-align: right;">1½</td> </tr> <tr> <td>(ii) Finding the ratio of closest approaches</td> <td style="text-align: right;">1½</td> </tr> </tbody> </table>	(a) (i) Name of spectral series	½	(ii) Calculation of λ_B	½ + ½	Calculation of λ_p	½ + ½	Calculation of ratio	½	(b) (i) Obtaining expression for distance of closest approach	1½	(ii) Finding the ratio of closest approaches	1½	½ ½ ½ ½ ½	
(a) (i) Name of spectral series	½														
(ii) Calculation of λ_B	½ + ½														
Calculation of λ_p	½ + ½														
Calculation of ratio	½														
(b) (i) Obtaining expression for distance of closest approach	1½														
(ii) Finding the ratio of closest approaches	1½														



	<p>(i) At the distance of closest approach.</p> $K = \frac{(Ze)2e}{4\pi\epsilon_0 d}$ $d = \frac{2Ze^2}{4\pi\epsilon_0 K}$ $d = \frac{2(Ze)q}{\frac{1}{2}mv^2 \times 4\pi\epsilon_0}$ $d = \frac{(Ze)q}{mv^2 \pi\epsilon_0}$ $d \propto \frac{q}{m}$ $\frac{d_p}{d_\alpha} = \frac{e}{2e} \times \frac{4m}{m} = \frac{2}{1}$	<p>1/2</p> <p>1</p> <p>1/2</p> <p>1/2</p> <p>1/2</p> <p>3</p>																	
28.	<table border="1" style="width: 100%;"> <tbody> <tr> <td>(a) (i) Answer</td> <td>1</td> </tr> <tr> <td>(ii) i. Calculation of distance</td> <td>1</td> </tr> <tr> <td>ii. calculation of angular spread</td> <td>1</td> </tr> </tbody> </table> <p>(i) slit formed by two blades</p> <p>(ii) (i) separation between two dark lines</p> $= \frac{2\lambda D}{d}$ $= \frac{2 \times 6000 \times 10^{-10} \times 1.5}{1 \times 10^{-4}} = 18 \times 10^{-3} m$ <p>(ii) $\phi = \frac{\lambda}{a}$</p> $= \frac{6000 \times 10^{-10}}{1 \times 10^{-4}}$ $= 6 \times 10^{-3} \text{ rad}$ <p style="text-align: center;">OR</p> <table border="1" style="width: 100%;"> <tbody> <tr> <td>(b) (i) Answer</td> <td>1/2</td> </tr> <tr> <td>Justification</td> <td>1/2</td> </tr> <tr> <td>(ii) Formula</td> <td>1/2</td> </tr> <tr> <td>Calculation</td> <td>1</td> </tr> <tr> <td>Answer</td> <td>1/2</td> </tr> </tbody> </table> <p>(b)</p> <p>(i) White.</p> <p>The interference pattern due to different component colors of white light overlap (incoherently). The central bright fringes for different colors are at the same position. Therefore the central fringe is white.</p>	(a) (i) Answer	1	(ii) i. Calculation of distance	1	ii. calculation of angular spread	1	(b) (i) Answer	1/2	Justification	1/2	(ii) Formula	1/2	Calculation	1	Answer	1/2	<p>1</p> <p>1/2</p> <p>1/2</p> <p>1/2</p> <p>1/2</p> <p>1/2</p> <p>1/2</p> <p>1/2</p>	
(a) (i) Answer	1																		
(ii) i. Calculation of distance	1																		
ii. calculation of angular spread	1																		
(b) (i) Answer	1/2																		
Justification	1/2																		
(ii) Formula	1/2																		
Calculation	1																		
Answer	1/2																		



	(ii) $\lambda_n = \frac{n\lambda D}{d}$ $\lambda = \frac{\lambda_n d}{nD}$ $\lambda = \frac{1.8 \times 10^{-2} \times 0.3 \times 10^{-3}}{6 \times 1.5}$ $\lambda = 6000 \text{ \AA}$	$\frac{1}{2}$ 1 $\frac{1}{2}$	3										
29.	<table border="1"> <tbody> <tr> <td>(a) Explanation</td> <td>1</td> </tr> <tr> <td>(b) Explanation</td> <td>1</td> </tr> <tr> <td>(c) Answer</td> <td>$\frac{1}{2}$</td> </tr> <tr> <td>Explanation</td> <td>$\frac{1}{2}$</td> </tr> </tbody> </table> <p>(a) It will not measure accurate value of current because its high resistance will affect the current in the circuit.</p> <p>(b) To reduce the galvanometer resistance a small resistance is connected in parallel.</p> <p>(c) It is less than the actual value of current because it has some resistance</p>	(a) Explanation	1	(b) Explanation	1	(c) Answer	$\frac{1}{2}$	Explanation	$\frac{1}{2}$	 1 1 1	3		
(a) Explanation	1												
(b) Explanation	1												
(c) Answer	$\frac{1}{2}$												
Explanation	$\frac{1}{2}$												
30.	<table border="1"> <tbody> <tr> <td>(a) Give reason for no current even with e.m.f. induced in loop</td> <td>1</td> </tr> <tr> <td>(b) Giving reason for damping of the copper plate</td> <td>1</td> </tr> <tr> <td>(c) Giving reason for no power consumption in pure inductor</td> <td>1</td> </tr> </tbody> </table> <p>(a) Even in the open loop e.m.f. can be induced but since circuit is open no current can flow.</p> <p>(b) When copper plate oscillates between poles of a strong magnet eddy currents are generated in the plate opposing the change in flux.</p> <p>(c) Power consumed by a pure inductor oscillates. For first half of the cycle it is positive and for the next half it is negative. So for a complete cycle it is zero.</p>	(a) Give reason for no current even with e.m.f. induced in loop	1	(b) Giving reason for damping of the copper plate	1	(c) Giving reason for no power consumption in pure inductor	1	 1 1 1	3				
(a) Give reason for no current even with e.m.f. induced in loop	1												
(b) Giving reason for damping of the copper plate	1												
(c) Giving reason for no power consumption in pure inductor	1												
SECTION-D													
31.	<table border="1"> <tbody> <tr> <td>(a) (i) Circuit diagram</td> <td>1</td> </tr> <tr> <td>I-V characteristics</td> <td>1</td> </tr> <tr> <td>Moving of threshold voltage</td> <td>$\frac{1}{2}$</td> </tr> <tr> <td>Significance of threshold voltage</td> <td>$\frac{1}{2}$</td> </tr> <tr> <td>(ii) Finding voltage difference between A and B</td> <td>2</td> </tr> </tbody> </table>	(a) (i) Circuit diagram	1	I-V characteristics	1	Moving of threshold voltage	$\frac{1}{2}$	Significance of threshold voltage	$\frac{1}{2}$	(ii) Finding voltage difference between A and B	2		
(a) (i) Circuit diagram	1												
I-V characteristics	1												
Moving of threshold voltage	$\frac{1}{2}$												
Significance of threshold voltage	$\frac{1}{2}$												
(ii) Finding voltage difference between A and B	2												



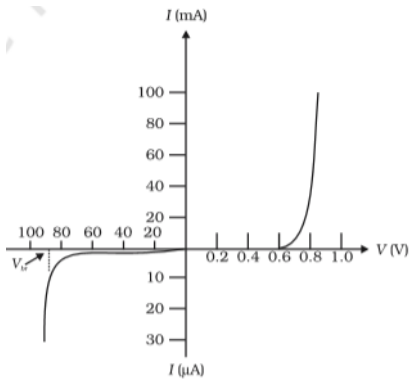
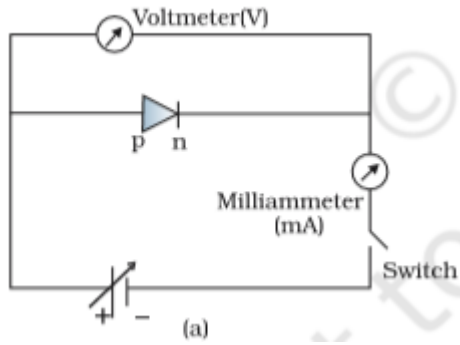

Beyond threshold voltage in forward bias diode current increases significantly even for very small increases in diode bias voltage.

$$(ii) V_A - 5 \times 10^3 \times 0.2 \times 10^{-3} - 0.3 - 5 \times 10^3 \times 0.2 \times 10^{-3} - V_B = 0$$

$$V_A - V_B = 2.3 \text{ volt}$$

OR

(b)

(i) Energy band diagrams	1 ½
Description	1 ½
(ii) Calculation of dynamic resistance	2

(i)

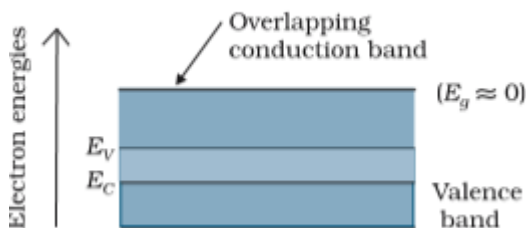

1

1

½

½

2

½

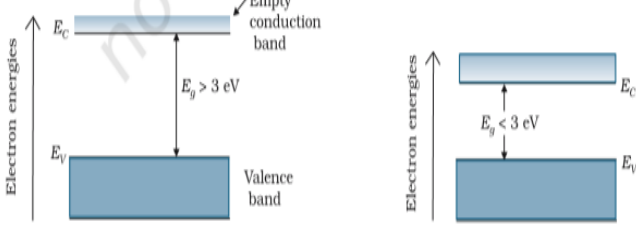
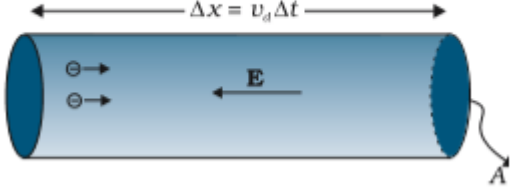
	 <p>For $E_g > 3\text{eV}$ material is insulate For $E_g < 3\text{eV}$ material is semiconductor For $E_g = 0$ or overlapping of conduction and valence band material is conductor.</p> <p>(ii) $r_d = \frac{\Delta V}{\Delta I} = \frac{0.7 - 0.6}{(20 - 10) \times 10^{-3}}$ $r_d = 10 \Omega$</p>	$\frac{1}{2} + \frac{1}{2}$ $\frac{1}{2} + \frac{1}{2} + \frac{1}{2}$ $\frac{1}{2} + \frac{1}{2}$ 1	5						
32.	<table border="1" data-bbox="279 855 1189 974"> <tbody> <tr> <td>(a) (i) Derivation of relation between I and V_d</td> <td>2</td> </tr> <tr> <td>Explanation</td> <td>1</td> </tr> <tr> <td>(ii) Calculating internal resistance of each battery</td> <td>2</td> </tr> </tbody> </table> <p>(a) (i)</p>  <p>Total charge transported across the area A in time Δt is $\Delta Q = -neA V_d \Delta t$ -----(1) Also the amount of charge crossing area 'A' in time Δt is $\Delta Q = I \Delta t$ -----(2) Comparing equation (1) and (2) $I = neA V_d$ With increase in temperature, average speed of electrons increases resulting in more frequent collisions Hence relaxation time τ decreases As $R = \frac{ml}{ne^2 \tau A}$ Resistance increases. (ii) For series $I = \frac{E}{R + r}$ $\frac{1}{2} = \frac{3}{R + 2r}$ $R + 2r = 6$ -----(1)</p>	(a) (i) Derivation of relation between I and V_d	2	Explanation	1	(ii) Calculating internal resistance of each battery	2	$\frac{1}{2}$ $\frac{1}{2}$ $\frac{1}{2}$ 1 $\frac{1}{2}$	
(a) (i) Derivation of relation between I and V_d	2								
Explanation	1								
(ii) Calculating internal resistance of each battery	2								

For parallel $\frac{1}{3} = \frac{1.5}{R + \frac{r}{2}}$

$2R + r = 9$ -----(2)

After solving $r = 1 \Omega$

OR

(b)

(i) Statement of Kirchhoff two rules	$\frac{1}{2} + \frac{1}{2}$
Obtaining the balanced condition	2
(ii) Finding current in branches MN, TO and SP	2

(i) Kirchhoff's junction rule - at any junction, the sum of the current entering the junction is equal to the sum of currents leaving the junction.

Kirchhoff second rule:

The algebraic sum of changes in potential around any closed loop involving resistors and cells in the loop is zero.

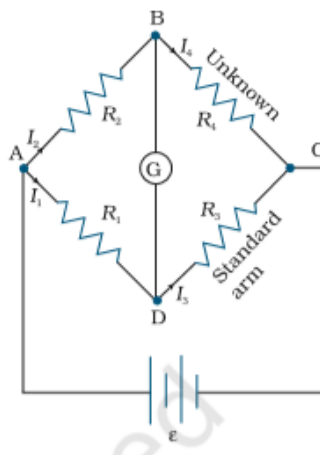

In balanced bridge $I_g = 0$,

Hence $I_1 = I_3$ and $I_2 = I_4$

Using Kirchhoff's loop rule for closed loops ADBA and CBDC

$-I_1R_1 + 0 + I_1R_1 = 0$ ($I_g = 0$) -----(1)

In the second loop $I_3 = I_1$, $I_4 = I_2$

$I_2R_4 + 0 - I_1R_3 = 0$ -----(2)

From equation (1) and (2)

$\frac{I_1}{I_2} = \frac{R_2}{R_1}$ and $\frac{I_1}{I_2} = \frac{R_4}{R_3}$

$\frac{R_2}{R_1} = \frac{R_4}{R_3}$

This is the condition for balanced Wheatstone bridge

$\frac{1}{2}$
1

$\frac{1}{2}$

$\frac{1}{2}$

$\frac{1}{2}$

$\frac{1}{2}$

$\frac{1}{2}$

$\frac{1}{2}$

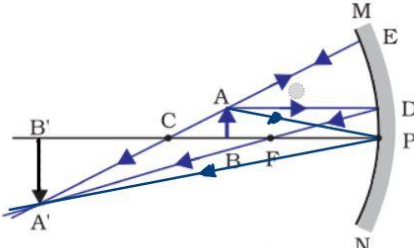
	<p>(ii) In loop MNOTM $2I + 4I_1 = 8$ -----(1) Loop OPSTO $-I + 5I_1 = -4$ -----(2) On solving Current in MN, $I = 4A$ Current in TO, $I_1 = 0A$ Current in SP, $I - I_1 = 4A$</p>	<p>$\frac{1}{2}$ $\frac{1}{2}$ 1</p>	<p>5</p>								
<p>33.</p>	<div style="border: 1px solid black; padding: 5px; margin-bottom: 10px;"> <p>(a)</p> <table style="width: 100%; border-collapse: collapse;"> <tr> <td style="width: 80%;">(i) Ray diagram</td> <td style="text-align: right;">1</td> </tr> <tr> <td style="padding-left: 20px;">Derivation of mirror equation</td> <td style="text-align: right;">2</td> </tr> <tr> <td>(ii) Finding the position of image</td> <td style="text-align: right;">$1\frac{1}{2}$</td> </tr> <tr> <td>Finding the nature of image</td> <td style="text-align: right;">$\frac{1}{2}$</td> </tr> </table> </div> <p>(a) (i)</p>  <p>From $\triangle A'B'C' \sim \triangle DPF$ $\frac{B'A'}{BA} = \frac{B'F}{FP}$ ($\because PD = AB$) -----(1)</p> <p>Form $\triangle A'B'P \sim \triangle ABP$ $\frac{B'A'}{BA} = \frac{B'P}{BP}$ -----(2)</p> <p>Comparing equation (1) and (2) $\frac{B'F}{FP} = \frac{B'P - FP}{FP} = \frac{B'P}{BP}$ Here $B'P = -v$ $FP = -f$ $BP = -u$ $\frac{-v + f}{-f} = \frac{-v}{-u}$ $\frac{v - f}{f} = \frac{v}{u}$</p>	(i) Ray diagram	1	Derivation of mirror equation	2	(ii) Finding the position of image	$1\frac{1}{2}$	Finding the nature of image	$\frac{1}{2}$	<p>1 $\frac{1}{2}$ $\frac{1}{2}$ $\frac{1}{2}$</p>	
(i) Ray diagram	1										
Derivation of mirror equation	2										
(ii) Finding the position of image	$1\frac{1}{2}$										
Finding the nature of image	$\frac{1}{2}$										

$$\frac{v}{f} = 1 + \frac{v}{u}$$

On solving we get

$$\frac{1}{f} = \frac{1}{v} + \frac{1}{u}$$

(ii) $u = -30 \text{ cm}$

$f = +12 \text{ cm}$

$$\frac{1}{f} = \frac{1}{v} + \frac{1}{u}$$

$$\frac{1}{v} = \frac{1}{f} - \frac{1}{u}$$

$$\frac{1}{v} = \frac{1}{12} + \frac{1}{30} = \frac{7}{60}$$

$$v = \frac{60}{7} \text{ cm}$$

Since v is positive image is virtual and erect.

OR

(b) (i) Ray diagram	1
Obtaining the expression for total magnification	2
(ii) Finding total magnification	2

(b) (i)

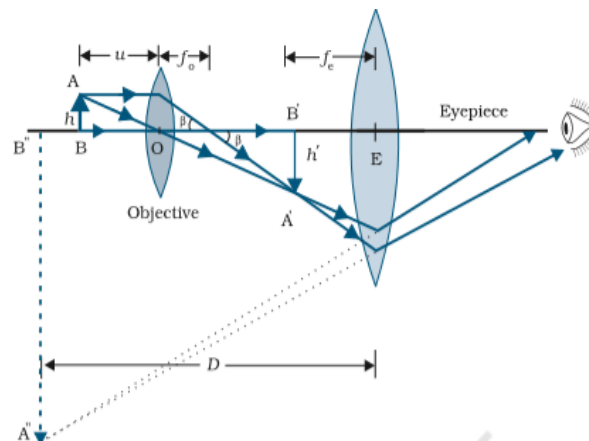

Magnification due to objective

$$m_o = \frac{h'}{h} = \frac{L}{f_o} \quad \left(\because \tan \beta = \frac{h}{f_o} = \frac{h'}{L} \right)$$

Magnification due to eye piece when final image is formed at the near point

1/2

1

1/2

1

1/2

	$m_e = 1 + \frac{D}{f_e}$ <p>Total magnification</p> $m = m_0 m_e$ $m = \frac{L}{f_0} \left(1 + \frac{D}{f_e} \right)$ $m = \frac{L}{f_0} \left(1 + \frac{D}{f_e} \right)$ <p>(ii) $m = \frac{LD}{f_o f_e}$</p> $m = \frac{24 \times 25}{2 \times 6} = \frac{600}{12} = 50$	<p>1/2</p> <p>1/2</p> <p>1/2</p> <p>1</p> <p>1</p>	5
	SECTION-E		
34.	<div style="border: 1px solid black; padding: 5px;"> <p>(a) Finding dielectric constant 1</p> <p>(b) Finding equivalent capacitance 1</p> <p>(c) Effect on potential difference and justification 1/2 + 1/2</p> <p style="padding-left: 20px;">Effect on energy stored and justification 1/2 + 1/2</p> <p style="text-align: center;">OR</p> <p>Calculation of effective capacitance 2</p> </div>	<p>1/2</p> <p>1/2</p> <p>1/2</p> <p>1/2</p> <p>1/2</p>	
	<p>(a) $K = \frac{C}{C_0}$</p> $K = \frac{80 \mu F}{10 \mu F} = 8$ <p>(b) $\frac{1}{C_s} = \frac{1}{C_1} + \frac{1}{C_2} + \dots + \frac{1}{C_n}$</p> $\frac{1}{C_s} = \frac{n}{C}$ $C_s = \frac{C}{n}$ <p>(c) Charge is constant</p> $Q_1 = Q_2$ $C_2 = K C_1$ $C_1 V_1 = K C_1 V_2$ $V_2 = \frac{V_1}{K} \quad \text{Potential diff decreases by a factor (1/K)}$	<p>1/2</p> <p>1/2</p> <p>1/2</p> <p>1/2</p> <p>1/2</p>	



	$U_2 = \frac{1}{2} \frac{Q^2}{C_2}$ $= \frac{1}{2} \frac{Q^2}{kC_1} = \frac{1}{k} \left(\frac{Q^2}{2C_2} \right)$ $U_2 = \frac{U_1}{K}$ <p>Energy reduces by a factor of 1/K.</p> <p style="text-align: center;">OR</p> <p>For calculating effective capacitance = 2 C.</p>	<p>½</p> <p>½</p> <p>½</p> <p>2</p>	<p>4</p>
<p>35.</p>	<div style="border: 1px solid black; padding: 5px; margin-bottom: 10px;"> <p>(a) Variation of δ with i 1</p> <p>(b) Derivation of equation for small angle prism 1</p> <p>(c) Calculation of μ in terms of A 2</p> <p style="text-align: center;">OR</p> <p>Calculation of angle of incident (i) 2</p> </div> <p>(a)</p> <div style="text-align: center;"> </div> <p>(b)</p> $\mu = \frac{\sin\left(\frac{A + \delta_m}{2}\right)}{\sin A / 2}$ <p>For small angle</p> $\mu = \frac{A + \delta_m}{A / 2}$ $\mu = \frac{A + \delta_m}{A}$ $\mu = 1 + \frac{\delta_m}{A}$ <p>(c) $i + e = A$</p>	<p>1</p> <p>½</p> <p>½</p>	

	$r = \frac{A}{2}$	$\frac{1}{2}$	
	$\mu = \frac{\sin i}{\sin r}$	$\frac{1}{2}$	
	$\mu = \frac{\sin A}{\sin A/2}$	$\frac{1}{2}$	
	$\mu = \frac{2 \sin(A/2) \cos(A/2)}{\sin(A/2)} = 2 \cos(A/2)$	$\frac{1}{2}$	
	OR		
	$\frac{\sin i}{\sin r} = \sqrt{2}$		
	$\frac{\sin r_2}{\sin 90^\circ} = \frac{1}{\sqrt{2}}$	$\frac{1}{2}$	
	$\sin r_2 = \frac{1}{\sqrt{2}}$		
	$r_2 = 45^\circ$	$\frac{1}{2}$	
	$r_1 + r_2 = A$		
	$r_1 + 45^\circ = 75^\circ$		
	$r_1 = 30^\circ$	$\frac{1}{2}$	
	$\frac{\sin i}{\sin r_1} = \sqrt{2}$		
	$\frac{\sin i}{\sin 30^\circ} = \sqrt{2}$		
	$\sin i = \sqrt{2} \times \frac{1}{2}$	$\frac{1}{2}$	
	$\sin i = \frac{1}{\sqrt{2}}$		
	$i = 45^\circ$		
			4

